

# WATER INFILTRATION MEASUREMENTS

The measure of infiltration of water into the soil is an important indication concerning: the efficiency of irrigation and drainage, optimizing the availability of water for plants, improving the yield of crops and minimizing erosion.

## 09.04 Double ring infiltrometer

The double ring infiltrometer is a simple instrument that is used to determine the rate of infiltration of water into the soil.

The rate of infiltration is determined as the amount of water per surface area and time unit, that penetrates the soil.

This rate can be calculated on the basis of the measuring results and the Law of Darcy.

The standard set of the double ring infiltrometer consists of a number of sets of stainless steel rings with different diameters (for reasons of transportation).

Several measurements can be executed simultaneously, yielding a very reliable and accurate mean result.

As vertically infiltrated water runs away to the sides, the outer ring of the infiltrometer serves as a separation. The measurements exclusively take place in the inner ring through which the water runs virtually vertical.

To achieve good measuring results it is important to take into account several factors that may influence the measurement: the surface vegetation, the extent to which the soil has been compacted, the soil moisture content and the soil layers (strata). The best measuring results are obtained at 'field capacity' of the soil.

The ring infiltrometer may be used for determining the rate of infiltration and capacity for irrigation and drainage projects, studying drainage, determining the intensity of artificial precipitation and the effect of treatment of the soil.



**P1.61**  
Parts List  
Pg 331

**The inner- and outer ring are driven a number of centimeters into the soil by means of a driving plate and an impact absorbing hammer.**



**Because the inner- as well as the outer ring are filled with water, the water flows virtually vertically through the inner ring into the soil.**

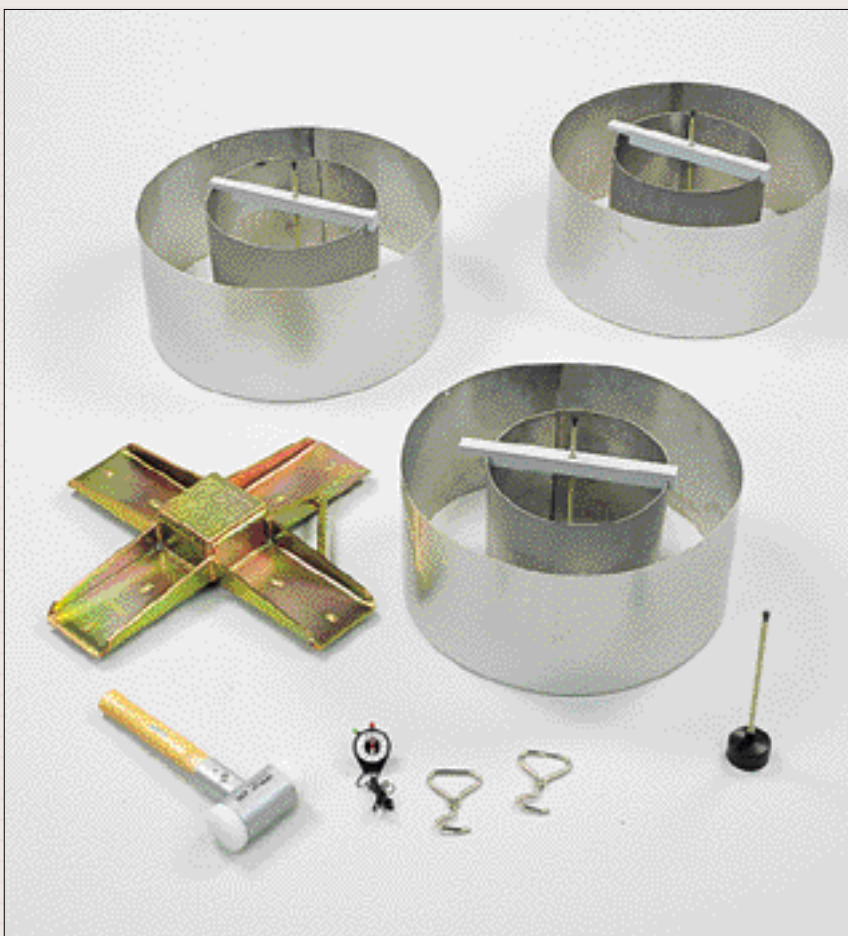

Double ring infiltrometer, complete set



**P1.61**  
Parts List  
Pg 332



# WATER INFILTRATION MEASUREMENTS

## 09.09 Tension infiltrometer

The tension infiltrometer measures the hydraulic properties of unsaturated soil. Water held under tension infiltrates into a dry soil through a highly permeable nylon membrane.

The time dependent infiltration rate is used to calculate unsaturated hydraulic conductivities and related hydraulic properties.

Infiltration rates are recorded manually.

With the pressure transducers, which can be connected to a datalogger, the rates can also be read electronically.

The pressure transducers can be attached to the top and the bottom of the water reservoir.

The standard set contains:

a tension infiltrometer with separate base plate, a small hand-operated vacuum pump for use during calibration, a metal ring and spare nylon mesh screens.

Pressure transducers and a datalogger are optional items (see P4.30).

## Advantages

- Separate infiltration disc for greater stability.
- On site determination of hydraulic properties.
- Low volume of water.
- 3 adjustable tension settings.
- Flow rates read directly from water column or with an optional tensimeter.
- Optional transducers and datalogger or tensi-recorder allow electronic data collection.
- Polycarbonate and plexi-glass materials.
- Replaceable nylon mesh screen membrane.

**The flow rate is read directly from the water column.**

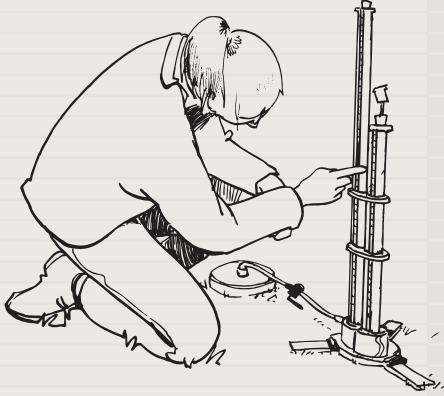

**The tension infiltrometer with pressure transducer is connected to a datalogger.**

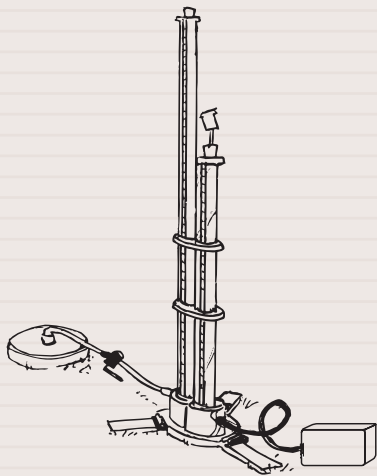

Tension infiltrometer, complete set