

5301

OPERATING INSTRUCTIONS

CURRENT TRANSDUCER

March 2005

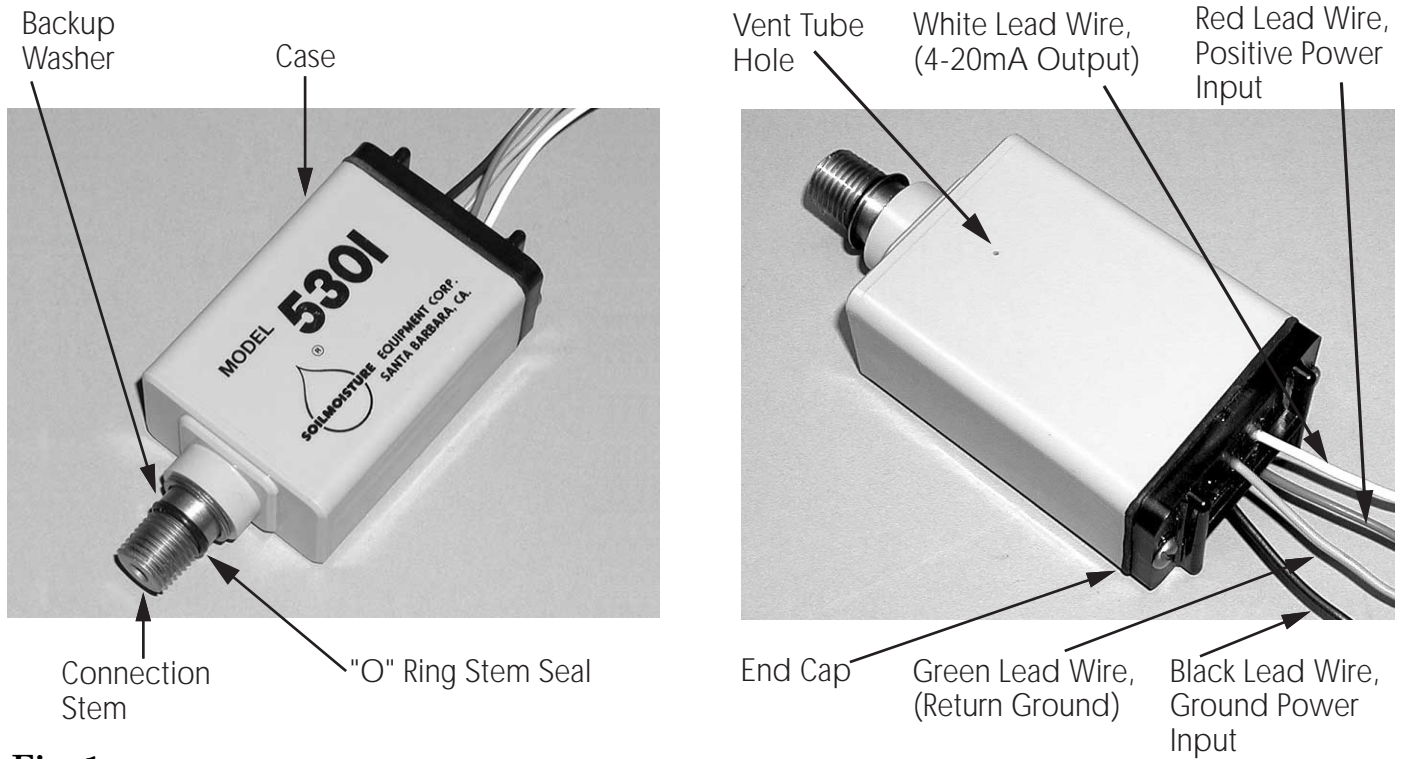

Fig. 1

UNPACKING	Page 2
SPECIFICATIONS	Page 2
ACQUAINT YOURSELF WITH THE PARTS	Page 3
MOUNTING THE TRANSDUCER SWITCH	Page 3
TESTING PRIOR TO INSTALLATION	Page 3
FIELD INSTALLATION	Page 4
SERVICING	Page 6
REPLACEMENT PARTS	Page 6

SOILMOISTURE EQUIPMENT CORP.

P.O. Box 30025, Santa Barbara, California 93105 USA

Telephone: (805) 964-3525 • Fax: (805) 683-2189

Website: <http://www.soilmoisture.com> • email: sales@soilmoisture.com



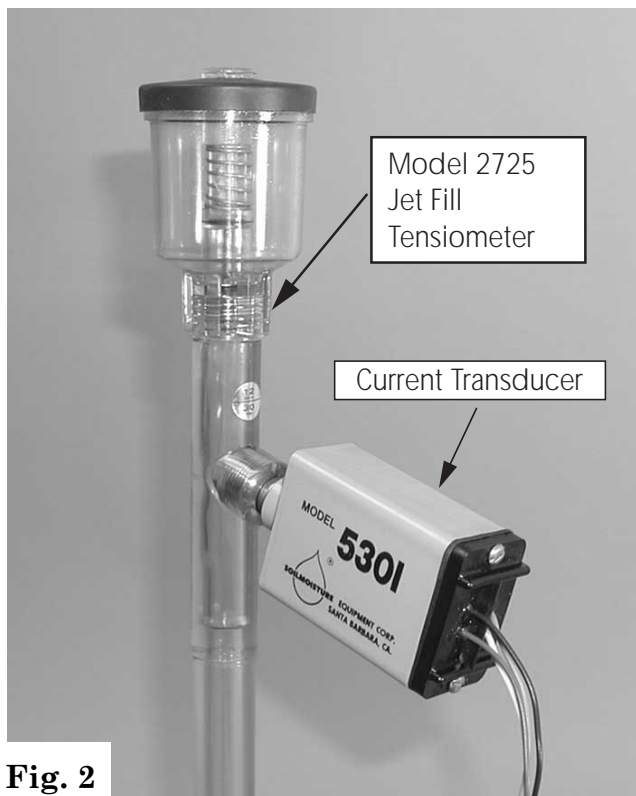

Fig. 2

The Model 5301 Current Transducer is one of the most advanced, versatile, accurate means converting soil moisture tension measurements into a continuous analog output. The Current Transducer can be readily used with Model 2100 Model 2710, Model 2725A and Model 2725AR Soilmoisture Tensiometers. Special adaptors are available to facilitate use of the Current Transducer with virtually any device, which measures vacuum. The standard Current Transducer incorporates a 0-1 bar range transducer and solid state circuitry which allows continuous monitoring of soil moisture suction with time. Optional Transducer elements with operating ranges of 0 to .1 bars and a to .5 bars are also available. The special four-wire design assures excellent linearity, accuracy of output, and ease of installations.

UNPACKING

The Model 5301 Current Transducer shipped to you has been thoroughly tested before shipment. When packed, it was in perfect order. Unpack with care being sure to remove all packing material. Follow the instructions carefully in order to assure long, trouble-free service.

If Jet Fill Tensiometers were ordered at the same time, the Current Transducer may be mounted on the tensiometer, see Fig. 2 above. In this case, you will also receive separate instruction for the tensiometers. Handle the complete units with Care and read all instruction information before installation.

NOTICE: ANY DAMAGE FOUND UPON RECEIPT SHOULD BE REPORTED IMMEDIATELY TO THE TRANSPORT CARRIER FOR CLAIM. IT IS IMPORTANT THAT YOU SAVE THE SHIPPING CONTAINER AND ALL EVIDENCE TO SUPPORT YOUR CLAIM.

Be sure to read all operating instructions thoroughly before operating unit.

SPECIFICATIONS

Power Requirement:	12 to 40 VDC at 50 mA. (Internally regulated)
Operating Range:	0 to 1 bar (15 PSI)
Operating Temperature Range:	32° to 140°F
Transducer Element:	Solid state) differential silicon shear stress/strain gauge.
Linearity:	.25% full scale max. (Typically +/- .1%)
Output:	4 to 20 mA.
Hysteresis:	Less than 1%
Maximum Pressure Differential:	2 bars (30 PSI)
Connecting Stem:	1/4" NPT Male

NOT LIABLE FOR IMPROPER USE

Soilmoisture Equipment Corp. is not responsible for any damage actual or inferred for misuse of improper handling of this equipment. The Current Transducer is designed to be used solely as directed, by a prudent individual under normal conditions in the applications intended for this instrument.

ACQUAINT YOURSELF WITH THE PARTS

Fig. 1 on the cover sheet shows several views of the Current Transducer. The rugged outer case protects and hermetically seals the electronic circuitry. The two screws in the End Cap hold the housing parts together and should not be loosened or removed at any time.

The power and output Lead wires come out of the End Cap through a soft rubber grommet that forms a her-metic seal. The power lead wires are red and black, and the analog output lead wires are green and white. The lead wires are connected as follows:

Red	Positive leads, power supply.
Black	Ground, power supply.
White	Positive lead, current output.
Green	Output return ground.

The small diameter hole in the underside of the covering case is the vent tube hole that vents one side of the transducer element to the atmosphere. Do not disturb or cover this hole at any time.

The Connection Stem projecting from the face of the Front Cap has a 1/4 NPT thread with a special "O" ring seal, and is used to connect the Transducer Switch to the tensiometer moisture sensing instrument.

MOUNTING THE CURRENT TRANSDUCER

If the Current Transducer has been ordered with Jet Fill Tensiometers as a complete assembly, the Current Transducer may have been shipped assembled to the tensiometer. If the Current Transducer has been packed separately it can be readily assembled to the tensiometer in the same manner as the normal vacuum dial gauge. Fig. 3 shows the assembly procedure.

When mounting the Current Transducer, be sure the threads on the Connection Stem of the transducer line up with the threads in the Plastic Body Tube of the tensiometer and that they enter easily. See Fig. 3. Screw the Current Transducer in clockwise, until the backup washer on stem touches body tube and then unscrew the current Transducer a portion of a turn until top of case is facing up. **DO NOT OVER TIGHTEN CURRENT TRANSDUCER IN BODY TUBE**, the "O" ring on the

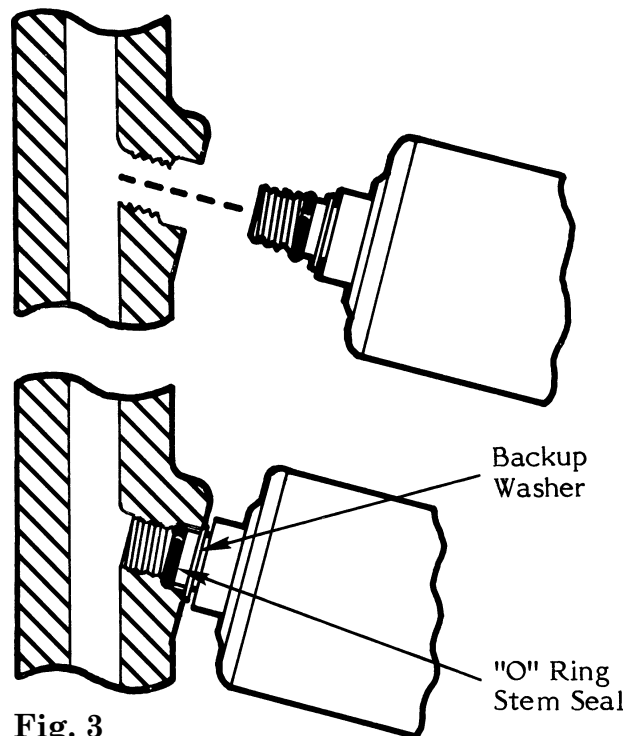

Fig. 3

stem of the Current Transducer makes the vacuum seal, not the threads.

TESTING PRIOR TO INSTALLATION

On initial installations, it is desirable to test the complete Tensiometer {Transducer assembly to verify that it is functioning correctly. Fig. 4 shows how this can be done using the Model 2005G2 Vacuum Test Hand Pump.

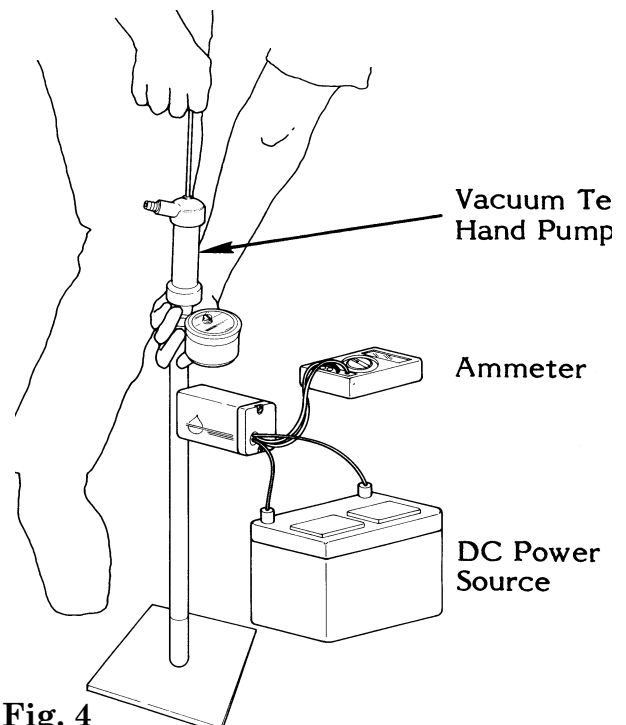
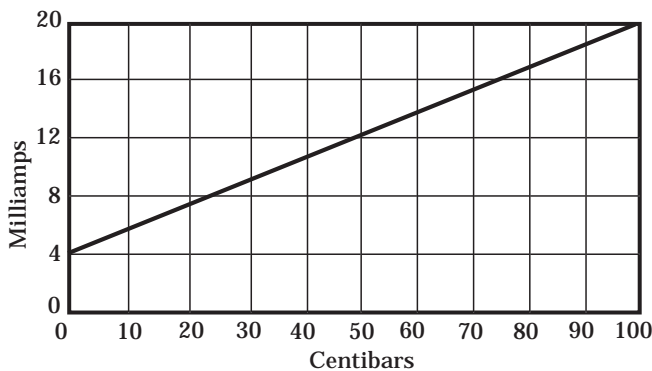

Fig. 4

First, dip the ceramic sensing tip of the tensiometer in water to fill the pores with water and seal off entry of air. Leaving the tip in water for a minute or two is sufficient. Remove the tensiometer cap and support the tensiometer so that the Vacuum Hand Pump can be inserted at the top of the unit. Connect the DC power source to the power leads of the Current Transducer and an ammeter to the output leads as described on page 1 under Acquaint Yourself With The Parts. When no vacuum is being applied, the ammeter should read 4 mA. In addition, the following calibration points are provided as check points:

Vacuum applied(cbs)	Ammeter Reading(mA)
0 cb	4 mA
25 cb	8 mA
50 cb	12 mA
75 cb	16 mA
100 cb	20 mA

The same relationship between Vacuum applied and Ammeter Readings is shown below graphically:



If the Model 2005G2 Vacuum Test Hand Pump is used in these tests, the vacuum level registered on the pump vacuum gauge will closely correlate with the ammeter readings shown above.

FIELD INSTALLATION

The tensiometer with attached Current Transducer is installed in the field in the same manner as vacuum gauge type tensiometers, and the specific instruction booklet covering the tensiometer used should be referred to for detailed information.

Where the Current Transducer is monitoring important irrigation installations, precaution can be taken to protect the switch from physi-

cal damage as well as tampering. There are a variety of meter boxes that are available on the open market that can be used. Fig. 5 shows a typical application.

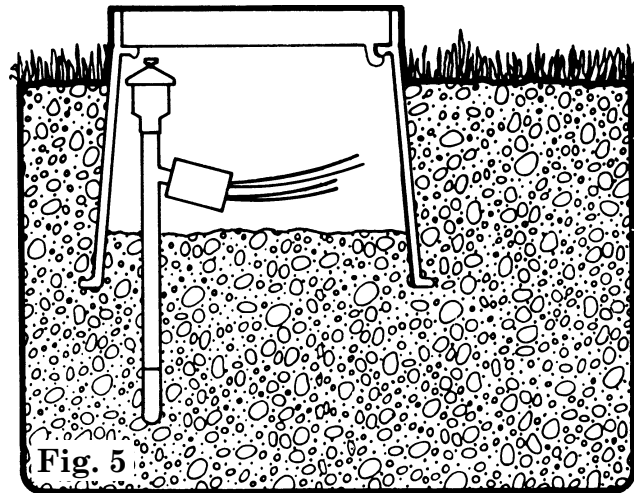

Fig. 5

It is important to remember that tensiometer measurements are based on the moisture level surrounding the sensing tip of the tensiometer. For this reason it is essential that the tensiometer be located so that it is subject to the same amount of irrigation or rain water that is delivered to the total area under investigation.

In some installations it may be desirable to install the tensiometer at an angle, as shown in Fig. 6, to best expose the sensing tip of the tensiometer to conditions typical of the irrigated area.

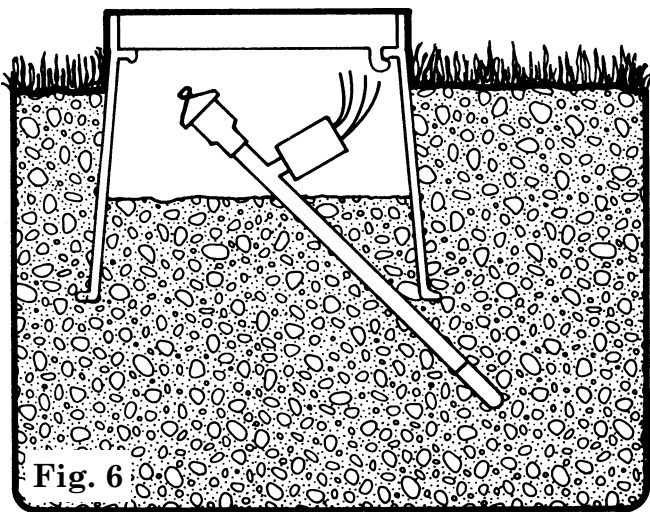

Fig. 6

Electrical connection to the Current Transducer is made in the same general manner as to other electrical components of an irrigation system that are exposed to field conditions.

Electrical connections must be water tight to avoid any electrical leakage during operation.

The 12 to 40 VDC power supply is connected to the power (red and black) lead wires and an ammeter or data logger connected to the output (white and green) wires.

Fig. 7 shows this simple direct application

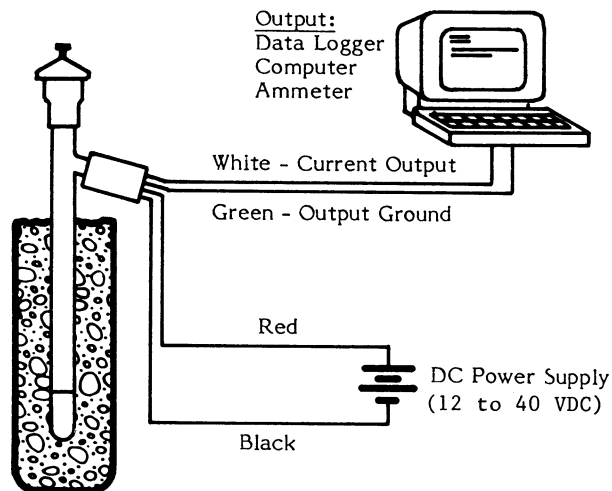

Fig. 7

Fig. 8 illustrates the minimum voltage supply required as related to the length of wire between the voltage supply and Model 5301 Current Transducer. The relationship is shown

for two gauges of wire, 18 A WG and 16 AWG. Note that the maximum recommended length of wire between the voltage supply and the Current Transducer is 1.5 miles.

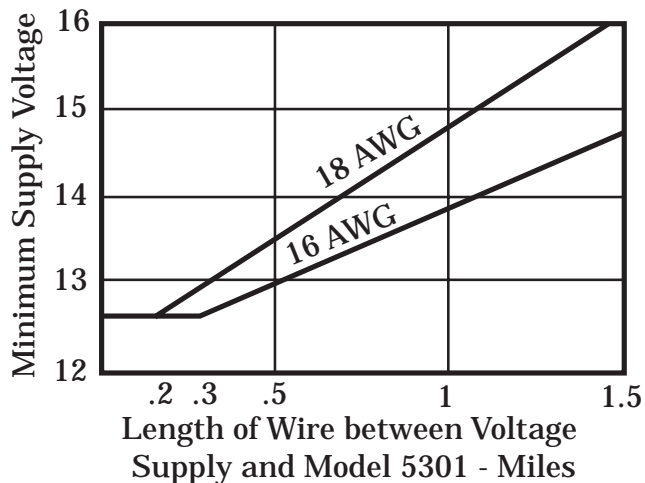

Fig. 8

The current output from Model 5301 Current Transducer is preferred because the output signal is unaffected by random lengths of wire between the Current Transducer and data logging device for distances up to 1 mile. For applications in which a voltage output is preferred, the current output from Model 5301 can be converted to a voltage output by use of a current to voltage converter. Fig. 9 shows a schematic of a current to voltage converter (source: National Semiconductor).

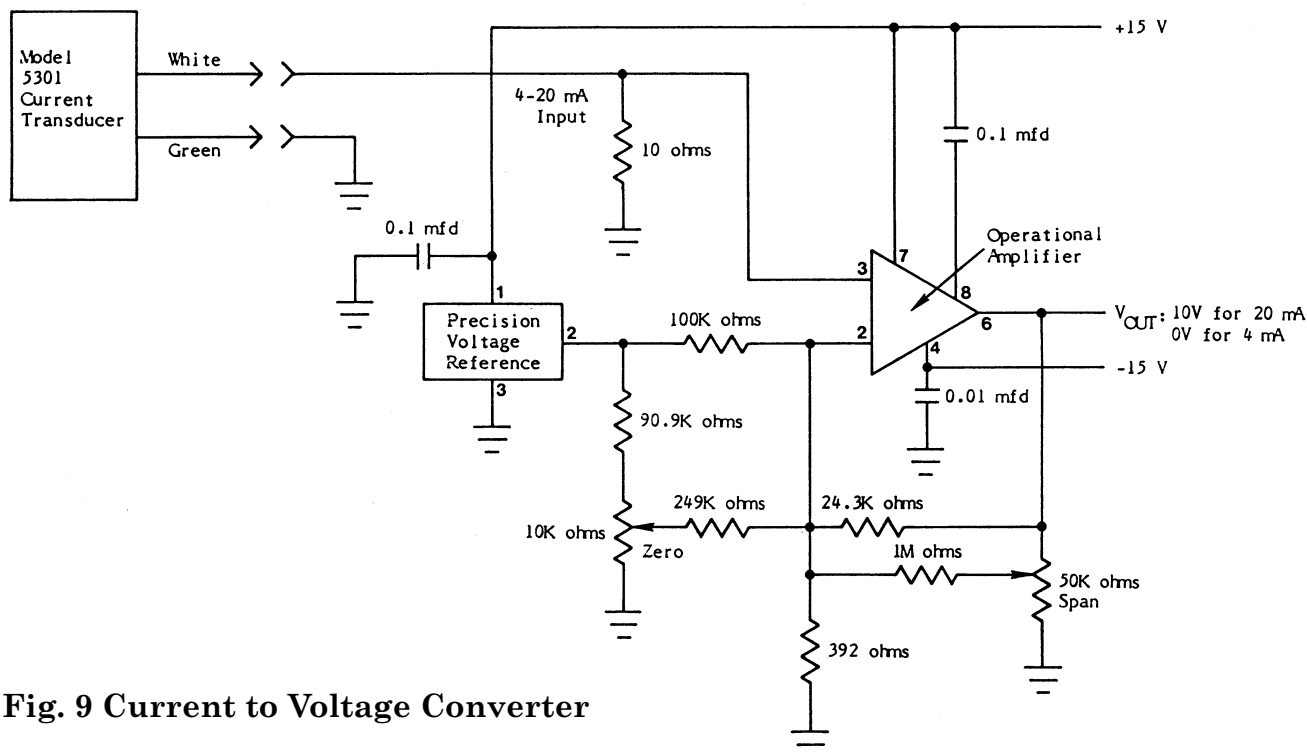

Fig. 9 Current to Voltage Converter

Once the current output is converted using the configuration in Fig. 9, the voltage output correlates with soil moisture tension and current output as shown below:

<u>Soilmoisture Tension</u>	<u>Current Output</u>	<u>Voltage Output</u>
0 cb	4 mA	0 V
25 cb	8 mA	2.5 V
50 cb	12 mA	5.0 V
75 cb	16 mA	7.5 V
100 cb	20 mA	10.0 V

SERVICING

The only servicing required is for occasional air removal from the tensiometer to maintain a high sensitivity. Specific instructions on the tensiometer should be referred to for this purpose.

The Current Transducer is of advanced electronic design and no repairs should be attempted in the field. The Current Transducer must be returned to the factory or authorized factory dealer for repairs. Opening the transducer - housing and breaking- the hermetic seal will void our guarantee.

REPLACEMENT PARTS

M801X013	"O" Ring Seal (Connecting Stem and Set Point Covers)
RW090CAS	Backup Washer